

IM-2-A7-PF0

Electrical specifications

Winding code : PF0	Symbol	Unit	Field weakening & Water cooling
Continuous torque	T_c	Nm	756
Continuous current	I_c	A_{rms}	70
Stall torque	T_s	Nm	634
Stall current	I_s	A_{rms}	56
Peak torque(for 1sec.)	T_p	Nm	1140
Peak current(for 1sec.)	I_p	A_{rms}	156
Torque constant	K_t	Nm/A_{rms}	12.12
Electrical time constant	T_e	ms	6.8
Resistance (line to line at 25°C)	R_{25}	Ω	0.4
Inductance (line to line)	L_d / L_q	mH	2.7 / 3.48
Number of poles	2p		66
Back emf constant (line to line)	K_v	$V_{rms}/rad/s$	7
Motor constant (at 25°C)	K_m	Nm/\sqrt{W}	15.65
Thermal resistance	R_{th}	K/W	0.036
Thermal sensor			PTC SNM100+SNM130+Pt1000
Max. DC BUS	V_{DC}		750
Inertia of rotor	J	kgm^2	0.355
Thermal time constant	T_{th}	s	130
Max. continuous power dissipation	P_c	W	4116
Max. peak power dissipation	P_p	W	20442
Max. speed(at 600VDC)		rpm	1850
Based speed(at 600VDC)		rpm	426
Rated speed(at 600VDC)		rpm	1818

T-N curve

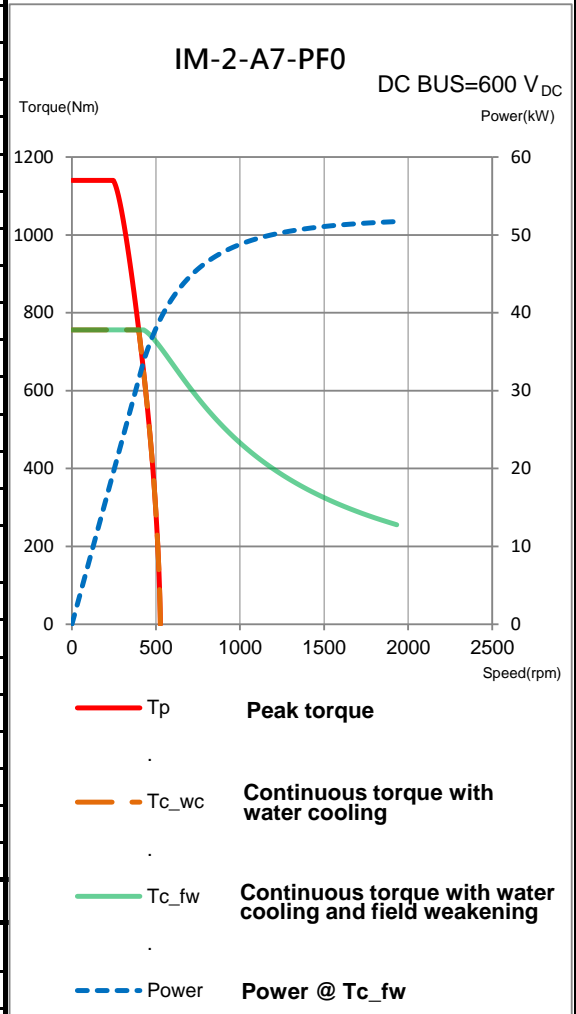

Mechanical specifications

	Symbol	Unit	Field weakening & Water cooling
Mass of rotor	M_r	kg	21.3
Mass of stator	M_s	kg	34.5
Height of stator	H_s	mm	130
Height of rotor	H_r	mm	91
Length of rotor centring fit	H	mm	20
Water temperature difference for P _c	$\Delta\theta$	K	5
Minimum water flow	q	l/min	11.8
Max. pressure drop	Δp	bar	1

Thermal sensor

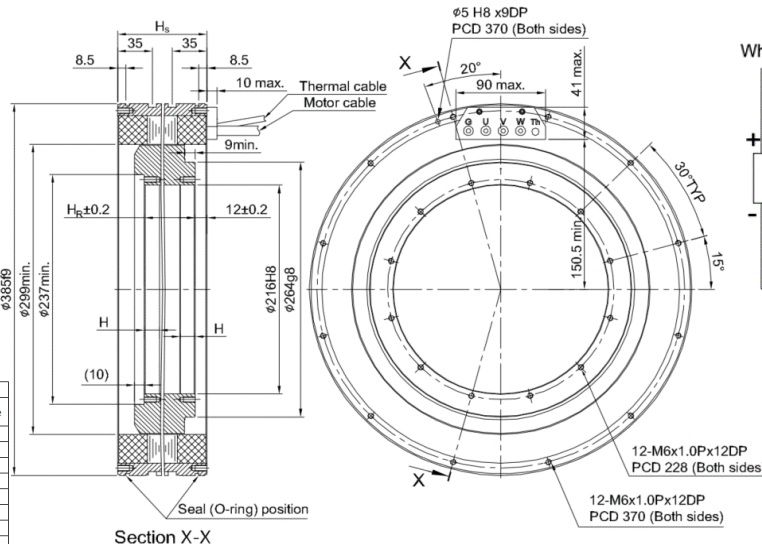

General tolerance mm	
Nominal dimension	Tolerance
~ 6	± 0.1
> 6 ~ 30	± 0.2
> 30 ~ 120	± 0.3
> 120 ~ 300	± 0.4
> 300 ~ 600	± 0.5
> 600 ~ 1200	± 0.8
> 1200 ~ 2400	± 1.0
> 2400	± 1.5

Motor wire table	
Color or wire no.	Signal
U/L1	PH U
V/L2	PH V
W/L3	PH W
Green/Yellow	GND

Except dimensions, all the specifications in the table are in $\pm 10\%$ of tolerance

Version: 2.00

This drawing is only for reference, detail dimensions please refer to approval drawing.

Date: 2020/11/4